

On/Off-grid Solar ESS User's Manual

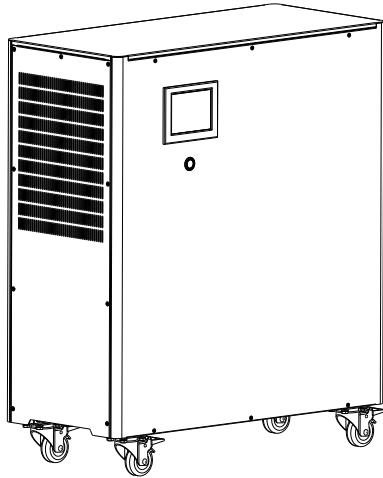

PS12050B Series

On/Off-Grid Hybrid Solar Energy Storage System

Thanks for using our products!

Please strictly follow the user's manual and pay attention to the warnings on the product.

Please do not operate before reading user's manual.

Contents

1. Brief Introduction	2
1.1 Foreword	2
1.2 Applicable Personnel	2
1.3 Safety Precautions	2
1.4 Use&Maintenance	2
2. Product Overview	3
2.1 Appearance	3
2.2 Back&Side Sketch	4
2.3 Power on/ off Introduction	4
3. Unpacking	4
4. Installation	5
4.1 Installation Precautions	5
4.2 Wiring Instructions	5
5. Operation	6
5.1 Operation Display Panel	6
5.2 Power On/Off	6
5.3 LCD Display and Operation	6
5.3.1 Initialization Interface	6
5.3.2 System Homepage	6
5.3.3 System Time Setting	7
5.3.4 User Setting Interface	7
5.3.5 System Information	9
5.3.6 Language Setting	9
5.3.7 Administrator System Setting	10
6. Functional Characteristics	16
6.1 Working Mode Features	16
6.2 Other Functional Characteristics	17
6.3 Power Off	17
7. Communication	18
8. Troubleshooting	18
9. Specifications	19
10. Contact	21

1. Brief Introduction

1.1 Foreword

This manual gives detailed product information and instructions for PV on/off-grid Hybrid Energy Storage System (ESS) (PS12050B series products). Please read this manual carefully before using them. And please safely keep the manual where is easily to get by user and maintainer.

1.2 Applicable Personnel

After reading the manual carefully, users can use PS12050B series products correctly and quickly, you can also make some troubleshooting and build a communication system.

Should any questions during installation, please contact your locally appointed technical supporter.

1.3 Safety Precautions

- (1) Please read the “Safety Precautions” before using to ensure right and safe operation and safely keep the manual. We have the rights of not offering quality assurance if the product fails when user doesn't follow this manual.
- (2) Please notice the warning marks and follow the manual during operation.
- (3) Keep the product away from sun, rain and humid conditions.
- (4) Keep the product away from heat source, like electric warming oven, furnace, etc.
- (5) Keep a safe distance for ventilation and follow the manual when installing.
- (6) This product is in the protection of the surge equipment level is very low, the installation of the PV into the line at the end of the increase in lightning protection device.
- (7) Once a fire, please use dry powder extinguisher for extinguishment because fluid extinguisher may cause electric shock hazard.
- (8) Please contact the local appointed installer or maintainer when maintenances needed.

1.4 Use&Maintenance

1. The working and store conditions influences the using life and reliability of this product, so please pay attention to avoid the following environment.

- Out of the specifications (temperature 0°C~40°C, relative humidity 5% to 90%) of high or low temperature and over humid place
- Please with vibrations or shocks
- Place with metal dust, corrosive substances, salt and flammable gases

2. Please use this product indoor only!

3. All electrical installation and maintenance shall be conducted by licensed electrician and shall comply with National wiring rules.

4. If do not use the device for a long time, please store it in a dry environment with temperature from -25°C to 55°C. Before use it again, please warm it up within

2. Product Overview

PS12050B Series is a small on/off-grid hybrid energy storage system, converting DC power from solar panels to AC electricity, feeding back to grid, charging built-in battery to store energy. Besides, the peak-avoiding working mode offers off peak electricity utilization.

It is an emergency power supply for TV or LED lights and other significant electrical devices when mains fail.

For areas without solar system, user can store power at night when electricity price is lower and use the stored power during day time when electricity price is high, which saves electricity charge.

The system can feed back electricity generated by solar panels to grid where on-grid is allowed.

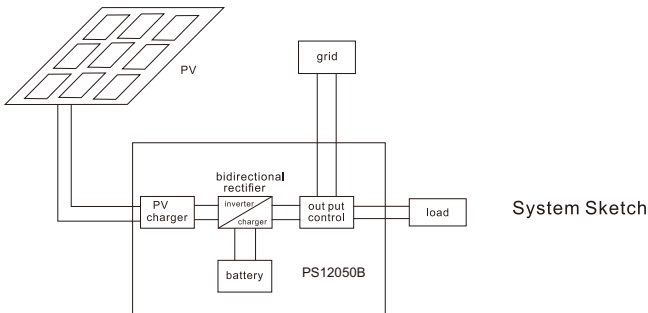

2.1 Appearance

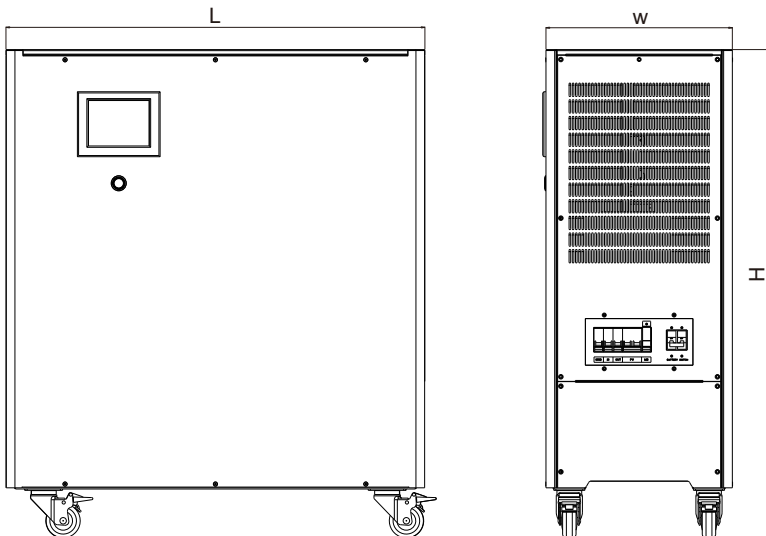

2.2 Back&Side Sketch

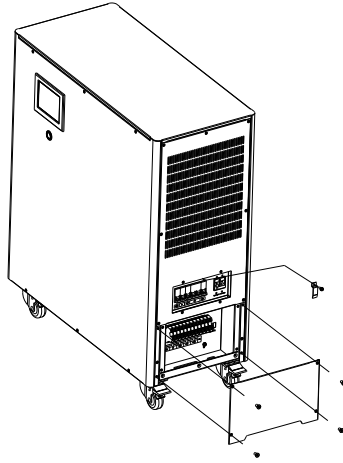

2.3 Power on/off Introduction

	GRID	Grid Input Switch
	SI	Outer Generator Input Switch
	OUT	AC Output Switch
	PV	PV Module Input Switch
	MB	Maintenance Bypass Switch
	Battery Switch	Battery Input Switch

3. Unpacking

Before opening the package, please check if the packaging is damaged. After unpacking, please check if product appearance is damaged or there is missing parts. If so, please contact us.

PS12050B Series products and accessories are as follows.

No	Item	Quantity
A	PV On & Off grid Energy Storage System	1
B	User's Manual	1
C	Warranty Card	1

4. Installation

4.1 Installation Precautions

1. Place the product where is well-ventilated and away from water, flammable gases, corrosive and other dangerous articles. Installation environment should meet the specified requirements.
2. Keep the air outlet on housing rear panel and the air intake on housing side unobstructed.
3. Low temperatures may cause condensation droplets in the product; user must wait for installation or use until inside and outside of the machine is dry completely. Otherwise there may be danger of electric shock.
4. PV module should be equipped with lightning protection devices.

4.2 Wiring Instructions

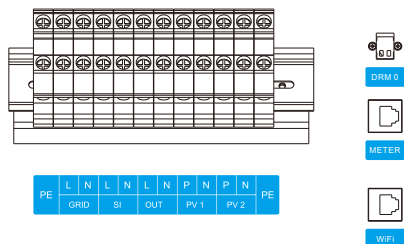

Please wiring according to below form.

PE	Ground Terminal	GRID-L	Grid Live Wire	GRID-N	Grid Null Wire
SI-L	Generator Live Wire	SI-N	Generator Null Wire	OUT-L	Load Output Live Wire
OUT-N	Load Output Null Wire	PV1-P	PV1 Input Positive	PV1-N	PV1 Input Negative
PV2-P	PV2 Input Positive	PV2-N	PV2 Input Negative	DRM 0	Base on AS 4777
Meter	Meter RS485	WiFi	WiFi RS485		

Note:

- (1) In general can only use the PV1, if you need to use two PV panel input, these two string PV panel number should be consistent.
- (2) Out terminal is connected to the load, can not be connected to the power grid.
- (3) SI terminal is not used.
- (4) Wire thickness should not be thinner than 10AWG.
- (5) SI function is optional.

5. Operation

5.1 Operation Display Panel

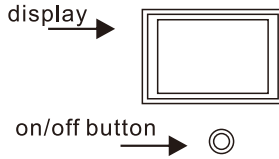

5.2 Power On/Off

(1) Power On: Press on/off button for one second or longer, the LCD display and button LED light on and system powers on

(2) Power Off: Press on/off button for three seconds or longer, the LCD display and button LED light off and system powers off

5.3 LCD Display and Operation

5.3.1 Initialization Interface

After power on, LCD display shows system initialization interface as below.

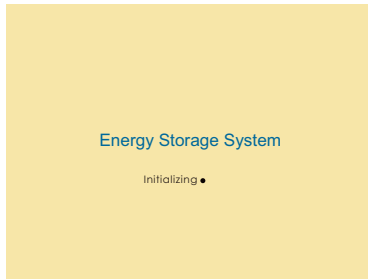

5.3.2 System Homepage

System homepage after Initialization

Touch the icons or works on LCD to see related information or setting parameters.

	Energy Running Path		System Status, including "running, standby failure"
off-grid mode	The bottom left words indicate the system current working mode. The other three modes : Energy-Saving Mode, Economical Mode and Peak-Avoiding Mode		
	PV modules Input Information		Battery Information
	Load/Output Information		Grid Input/Output Information
	Maintenance Setting Interface	"Setting"	User's Setting Interface
	Battery Information		
"System Info"	System Running Status	"Language"	Language Setting

5.3.3 System Time Setting

The bottom right corner of system homepage displays system time and touch the related area to set system time.

5.3.4 User Setting Interface

Touch “Setting” area of system homepage to user’s setting interface.

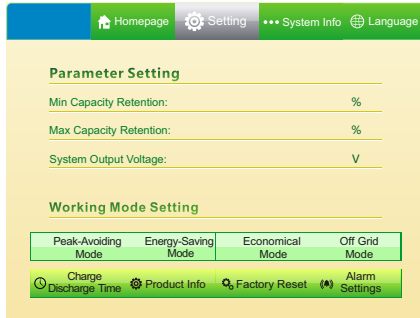

Touch the number after "Min Capacity Retention "to set minimum battery capacity retention percentage

Touch the number after "Max Capacity Retention "to set maximum battery capacity retention percentage

Touch the number after "System Output Voltage "to set System AC output Voltage

5.3.4.1 Working Mode Setting

Choose one from four working modes from Peak-Avoiding Mode, Energy-Saving Mode, Economical Mode and Off Grid Mode.

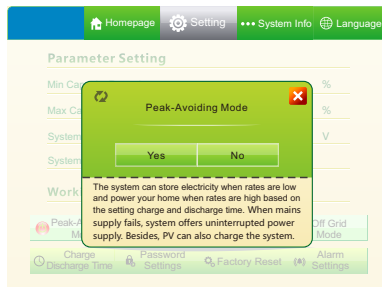

Touch “Yes” or “No” to confirm or back respectively.

5.3.4.2 Peak-Avoiding Mode Setting

After confirming Peak-Avoiding Mode, next step should be set the Peak-Avoiding time.

Touch “Peak-Avoiding Time” below “Peak-Avoiding Mode”.

Charge Time		
Start	H	M
End	H	M

Discharge Time		
Start	H	M
End	H	M

5.3.4.3 Factory Reset Setting

Factory Reset

Yes No

5.3.4.4 Alarm/Buzzer Setting

Buzzer On/Off

Yes No

5.3.5 System Information

Touch “System Info” area on system homepage to check system running status and alarm information.

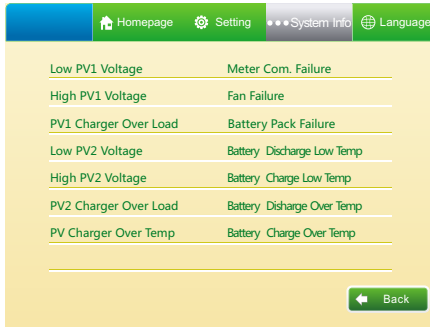
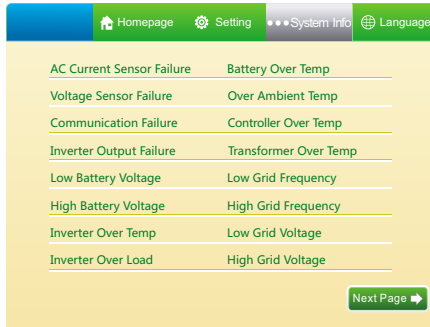

5.3.6 Language Setting

Touch “Language” area on system homepage to set system language.

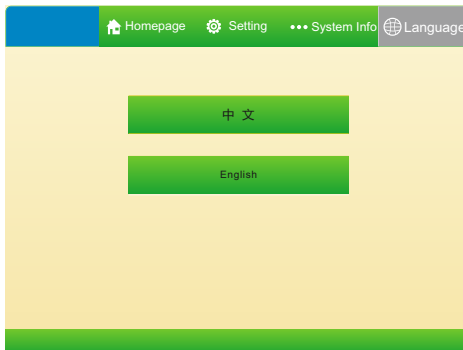

5.3.7 Administrator System Setting

Touch  on system homepage and input passwords to administrator setting page.



Note: administrator setting is only for professional, maintainer or other after-service technician.

Type in correct password to access and next page as below.

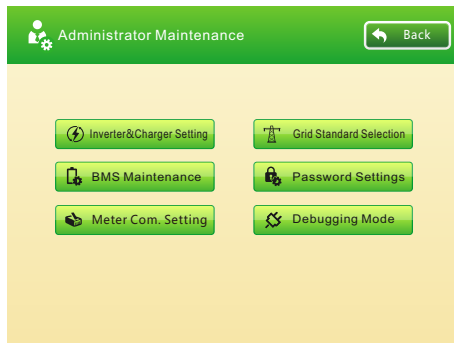

5.3.7.1 Bi-directional Inverter Setting

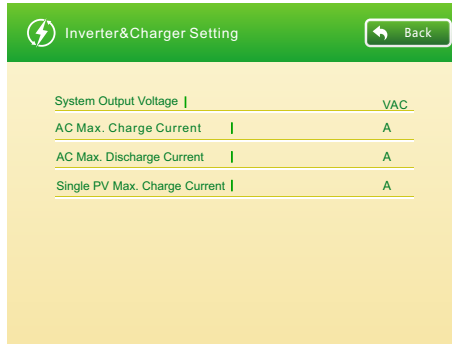

“Inverter Maximum Charge Current” stands for battery maximum charge current from grid.
“Inverter Maximum Discharge Current” stands for the maximum feedback current to grid.
“PV Maximum Charge Current” refers to the maximum charge current for battery from PV module.

5.3.7.2 BMS Setting

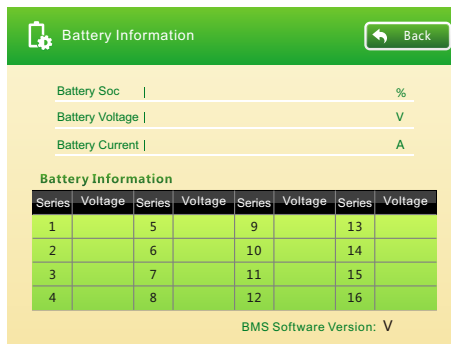

This page tells detailed battery information including battery single cell voltage.

5.3.7.3 Energy Meter Communication Setting

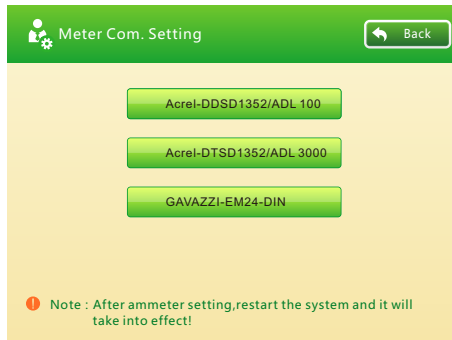

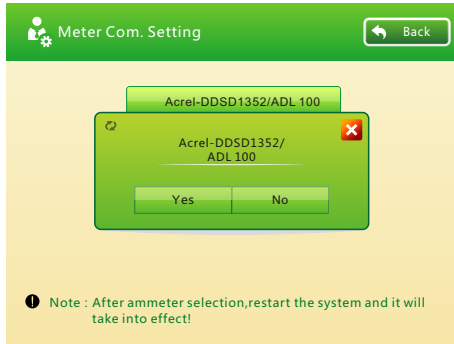

Users can set the meter model that matches the system from this page.

5.3.7.4 Password Setting



The default password is 123456. Only administrator is supposed to change or set these passwords. If the passwords are forgotten, user can touch “Setting” in homepage, then touch “Factory Reset” to reset these passwords to default passwords .

Note: When the user enter the wrong password three times, the system automatically put the password to the factory password

5.3.7.5 Forced Charge/Discharge Setting



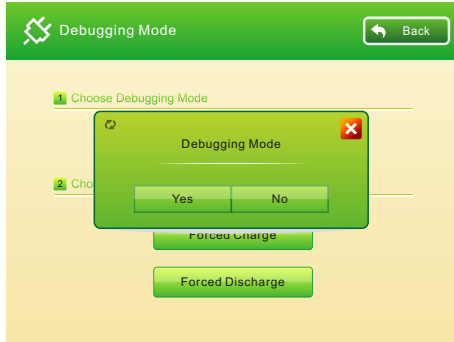

Maintainer can force the system to charge battery from AC power supply or discharge, and can also enter debug mode .

5.3.7.6 Grid Standard Selection

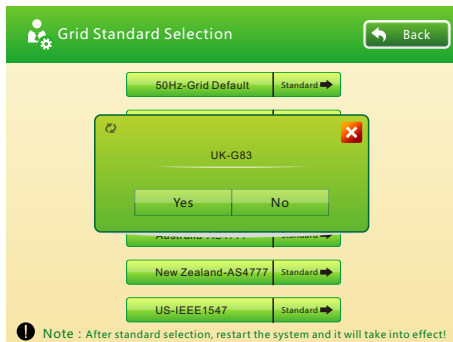

Users can set the Grid Standard from this page.

5.3.7.7 Grid Standard

Touch  to read the grid standard information from this page.

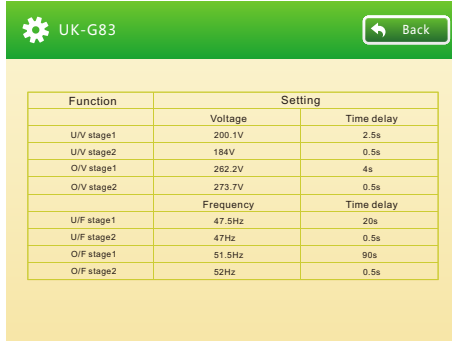

The screen displays the title "UK-G83" and a "Back" button. Below is a table with the following data:

Function	Setting	
	Voltage	Time delay
U/V stage1	200.1V	2.5s
U/V stage2	184V	0.5s
O/V stage1	262.2V	4s
O/V stage2	273.7V	0.5s
	Frequency	Time delay
U/F stage1	47.5Hz	20s
U/F stage2	47Hz	0.5s
O/F stage1	51.5Hz	90s
O/F stage2	52Hz	0.5s

Touch "Australia-AS4777"  to read the grid standard information from this page.



The screen displays the title "Australia-AS4777" and a "Back" button. Below is a table with the following data:

Function	Setting	
	Voltage	OVP
LVP		180V
OVR		253V
LVR		204.7V
Frequency	OFP	52Hz
	LFP	47Hz
	OFR	50.15Hz
	LFR	47.5Hz

At the bottom right, there is a button labeled "On Grid Setting" with a right-pointing arrow.

Touch "" to choose On Grid Mode .



The screen displays the title "On Grid Parameter Setting" and a "Back" button. It contains several parameter settings:

- DRM0 On/Off
- Grid Response On/Off
- Volt-Watt Response Mode
- Volt-Var Response Mode
- Power-PF Response Mode
- Power Rate Limit Mode
- Fixed-Var P_{var}= 1500
- Fixed-PF PF= 1.00

Note : After grid parameter setting, restart the system and it will take into effect!

DRM0 Setting

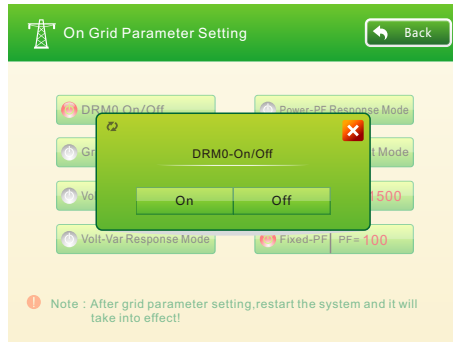

Touch "On" or "Off" to set DRM0 testing function.

Fixed-Var Mode

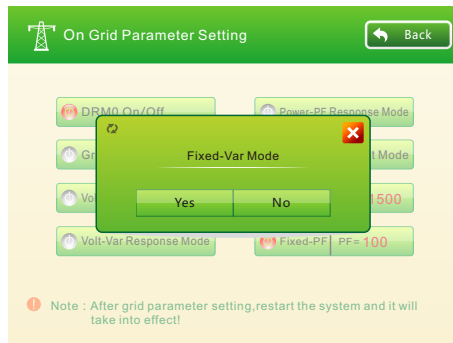

*P_{var}: 0~1800W , PF: ±80%

6. Functional Characteristics

6.1 Working Mode Features

Under any certain working mode, system use solar energy firstly and choose energy source automatically based the custom setting parameters or defaults. Besides, system offers uninterrupted power supply automatically when mains fail.

6.1.1 Peak-Avoiding Mode

The system can store electricity when rates are low and power your home when rates are high based on the setting charge and discharge time. When mains supply

6.1.2 Energy-Saving Mode

Solar generation satisfies home needs and surplus energy doesn't feed back to grid. When mains supply fails, system offers uninterrupted power supply automatically.

When ESS unit is connected to the grid and the meter, the ESS system will enter the state of meter matching, and the battery power will run till the minimum retention percentage set by the user.

6.1.3 Economical Mode

Solar generation satisfies home needs and surplus energy feeds back to grid for profit. When mains supply fails, system offers uninterrupted power supply automatically.

When ESS unit is connected to the grid and the meter, the ESS system will enter the state of meter matching, and the battery power will run till the minimum retention percentage set by the user.

6.1.4 Off-grid Mode

System doesn't feed energy back to grid. When mains supply fails, system offers uninterrupted power supply automatically.

6.2 Other Functional Characteristics

6.2.1 Illustration of the state of meter matching:

ESS units are with a meter matching function, system will enter the state of meter matching once end users select the correct meter model and make the correct wiring. When the meter value is "positive" (loads on the grid), the ESS unit will discharge the load power to the grid, to make the meter value to "0".

6.2.2 When there is no input for solar panels or grid and the battery capacity is lower its 10%, the system will shut down the output to protect battery from low discharge. And the system will shut down automatically if there is still no input in 10 minutes.

6.2.3 After the system shutting down because of low battery capacity, if there is input from grid or solar panels, system will turn on automatically and keep operating on previous working mode.

6.2.4 After the system shutting down because of low battery capacity, if there is only input from solar panels, the system will restart output automatically after battery capacity

6.3 Power Off

If the machine need be shut down thoroughly, eg for long term storage, the operation steps as Below.

1. Open the wire -in cover at the right side of metal housing, turn off breakers, cially thePV input breaker and grid input breaker. The system won 't be shut down if there is any input from solar panels or grid.
2. Touch  on LCD homepage, choose "standby", then press and hold on the nded button under LCD display until the button indicator turns off. Then the machine shuts down totally .

7. Communication

The product offer RS-485 communication interface and the interface definition as follows

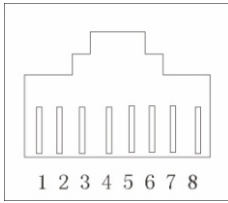

Meter

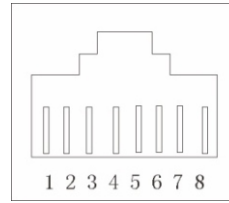

WiFi

Meter:

No.	Item	No.	Item	No.	Item	No.	Item
1	RS485 B	2	RS485 A	3	NC	4	NC
5	GND	6	GND	7	NC	8	NC

WiFi:

No.	Item	No.	Item	No.	Item	No.	Item
1	NC	2	NC	3	RS485 B-2	4	RS485 A-2
5	GND	6	GND	7	NC	8	NC

8. Troubleshooting

Our products have been tested strictly before delivery. If you have any difficulty during installation or operation, please contact your local technical supporter or contact us.

When the machine fails, please inform us and provide product related information. We have professional after-sale service staff to respond.

Information as follows

For our product

- LCD display alarm information
- Grid voltage
- DC input voltage
- Can you repeat this failure problem?
- Did this problem happen before?
- What probably caused this problem?

For PV module

- Solar panels manufacturer name and Model number
- Solar panels output power
- Solar panels output voltage
- Solar panels MPPT output voltage
- Solar panels MPPT output current
- Solar panel quantity

9. Specifications

Model	PS12050B
System Storage Capacity	12000Wh
System Work Model	On&Off Grid Hybrid
UPS Function	Yes
AC Input	
Nominal AC Input Power	5000W
Maximum Input Current	37A
AC Voltage range ^①	180~260Vac
AC Output	
Nominal AC Output Power (Off Grid)	5000W
Nominal AC Output Power (On Grid)	4600W
Maximum AC Output Power	7500W
AC Voltage Nominal Inverter Voltage	230Vac
Nominal Frequency	50/60Hz
Nominal Inverter Output Current	21.7A
Maximum Inverter Output Current(Nominal Inverter Voltage)	32.6A
Overload	100%<Load>110%@10min; 110%<Load>150%@10s
Feed Back to Grid	Yes(Default)
Energy Consumption	Intelligent Control
Maximum Efficiency	> 92.5%

① Grid interaction standard defines the voltage range of grid charging ESS and ESS feeding back to grid.

Model	PS12050B
PV Input	
Maximum Input Power	2700W*2(Total 5400W)
Start-up Voltage	70V
MTTP Strings Amount	2
MTTP Voltage Range	70V-140V
Maximum Input Current	39A*2(39A Single)
Maximum Input Voltage	150V
Maximum Efficiency	>97%
I-feedback	0A
Isc. PV(Short-circuit current)	45A*2(45A Single)
BATTERY	
Battery Management System	Yes
Rated Capacity	225Ah
Battery Type	Li-ion
Maximum Charge Voltage	58.5V
Discharge Cut-Off Voltage	42V
Maximum Charge Current	100A
ELECTRICAL PROTECTIONS	
DC/AC protection	Yes
DC Lightning Arrester	Yes
Batteries protection	Fuse

Model	PS12050B
GENERAL	
IP Protection	IP21
Connectivity	Cable Terminals
Communication	RS485
Using Conditions	Humidity:5%-90%
	Temperature: 0-45°C
Warranty	2years, 5years Optional
Ventilation Location	Side
Dimensions (mm)	L780*W392*H920
Net weight	208Kg
Gross weight	242Kg

* Any further changes without prior notice!

10. Contact

Should you have any technical questions, please contact your installer.

Following information needed:

1. Model Number
2. Module Information
3. Communication way
4. Series Number
5. Error Information
6. Display information

